

LINE OUTPUT TRANSFORMER 1:1 BIFILAR WINDINGS

- Low profile allows PCB mounting with 1" board spacings
- Low Distortion - 0.0075% typ at 20 Hz and 0 dBm output level
- Excellent Frequency Response - ± 0.15 dB from 20Hz to 20kHz
- Meets the requirements of UL 94V-0
- Deviation from Linear Phase 0.1° typical from 20 Hz to 20 kHz

This transformer is designed for high performance 600 Ohm output stages. Specially processed 80% nickel alloy core material is used for lowest possible harmonic distortion of low frequency signals. For optimum performance, driving signals should be free of DC and source impedance should be 50 Ohms.

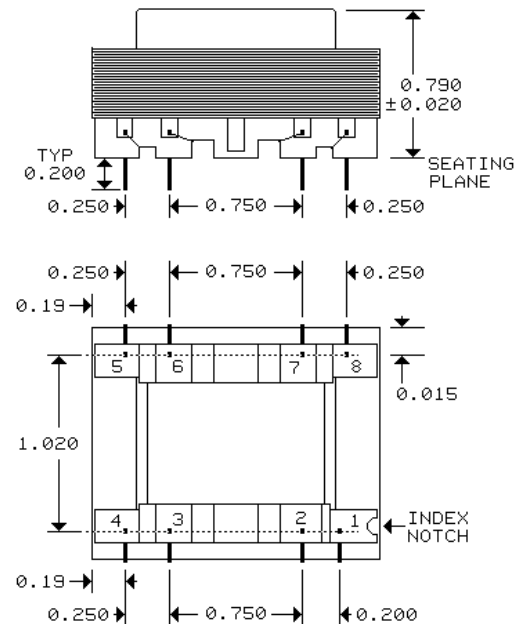
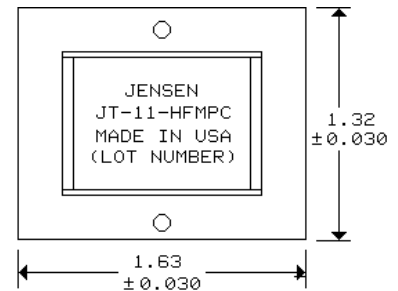

PIN NUMBERS NOT MARKED ON PART
PINS ARE 0.025 SQUARE, 8 PLACES
0.040 DIA PC HOLES RECOMMENDED

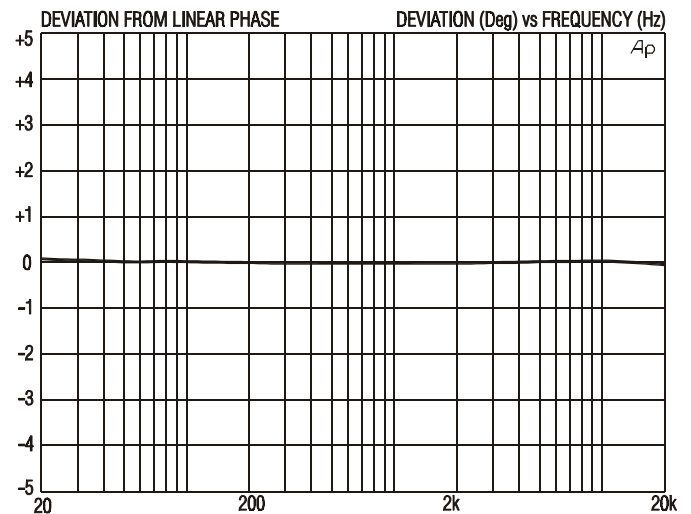
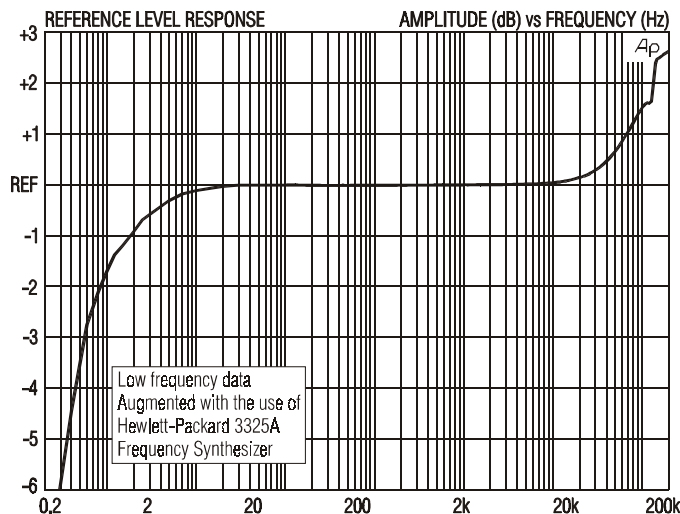
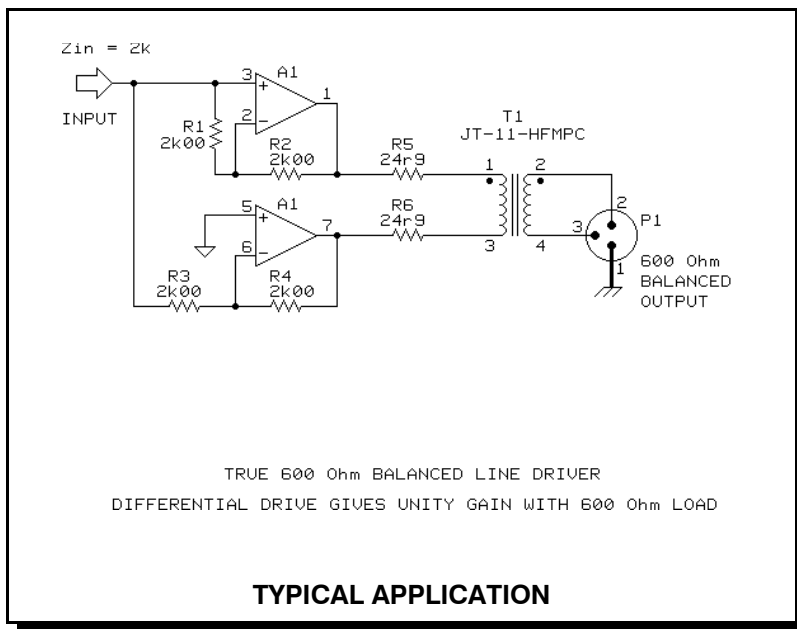

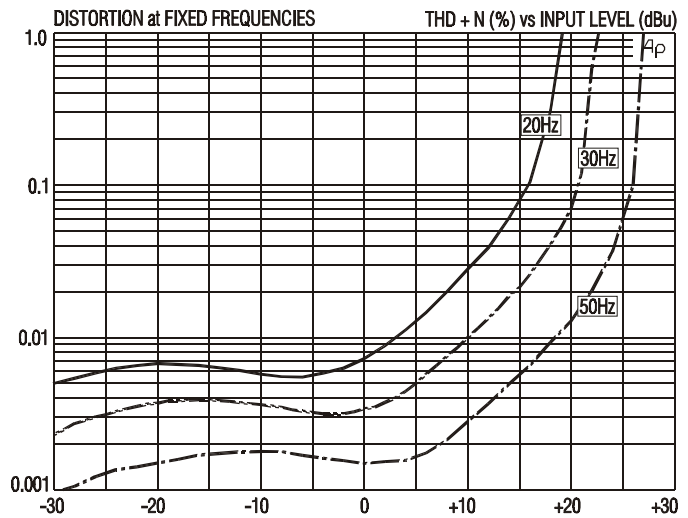
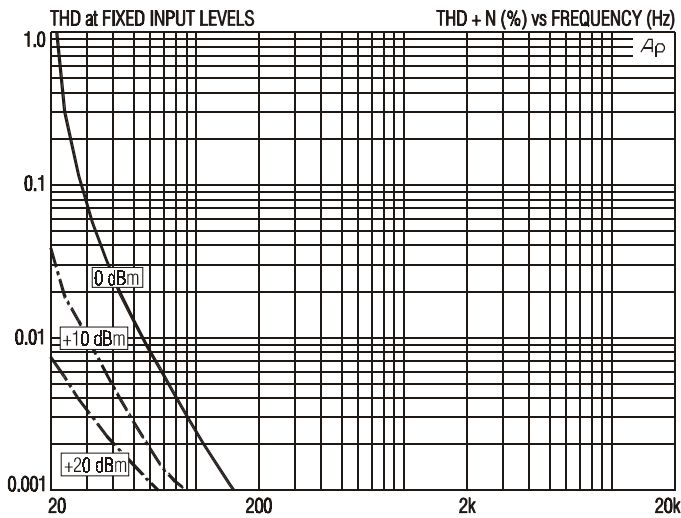

JT-11-HFMPC SPECIFICATIONS (all levels are output unless noted)

PARAMETER	CONDITIONS	MINIMUM	TYPICAL	MAXIMUM
Reference Output Level	1 kHz, 6.02dBm Generator Source Level, test circuit 1	-0.20 dBm	0.00 dBm	+0.20 dBm
Magnitude response, ref 1 kHz	20 Hz, 0 dBm, test circuit 1	-0.10 dB	-0.01 dB	0.00 dB
	20 kHz, 0 dBm, test circuit 1	+0.04 dB	+0.14 dB	+0.24 dB
Deviation from linear phase (DLP)	20 Hz to 20 kHz, 0 dBm, test circuit 1		$\pm 0.1^\circ$	$\pm 0.5^\circ$
Distortion (THD)	1 kHz, 0 dBm, test circuit 1		<0.001%	
	20 Hz, 0 dBm, test circuit 1		0.008%	0.03%
Maximum output level	20 Hz, 1% THD, test circuit 1		+18.5 dBm	
	30 Hz, 1% THD, test circuit 1	+21.0 dBm	+22.5 dBm	
Common-mode rejection ratio (CMRR)	60 Hz, test circuit 2		85 dB	
	3 kHz, test circuit 2	40 dB	50 dB	
Input impedance, Zi	20 Hz to 20 kHz, 0dBm, test circuit 3		1.07k Ω	
Output impedance, Zo	20 Hz to 20 kHz, 0dBm, test circuit 4	575 Ω	600 Ω	615 Ω
DC resistance	primary winding		240 Ω	
	secondary winding		310 Ω	
Capacitance	winding to winding, 1 kHz		37 nF	
Turns ratio		0.999:1	1.000:1	1.001:1
Temperature range	operation or storage	0° C		70° C
Breakdown voltage, 60 Hz, 1 min. duration (see IMPORTANT NOTE below)	winding to winding	250 V RMS		

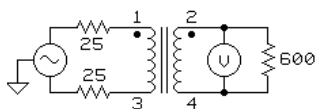

TEST CIRCUIT 1

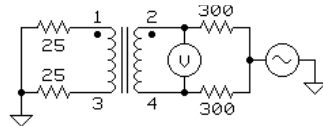

TEST CIRCUIT 2

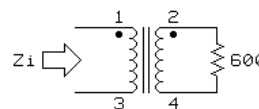

TEST CIRCUIT 3

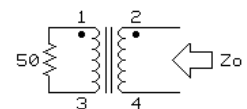

TEST CIRCUIT 4

All minimum and maximum specifications are guaranteed. Unless noted otherwise, all specifications apply at 25°C. Specifications subject to change without notice. All information herein is believed to be accurate and reliable, however no responsibility is assumed for its use nor for any infringements of patents which may result from its use. No license is granted by implication or otherwise under any patent or patent rights of Jensen Transformers, Inc.

IMPORTANT NOTE: This device is NOT intended for use in life support systems or any application where its failure could cause injury or death. The breakdown voltage specification is intended to insure integrity of internal insulation systems; continuous operation at these voltages is NOT recommended. Consult our applications engineering department if you have special requirements.

JENSEN TRANSFORMERS, INC., 7135 Hayvenhurst Avenue, Van Nuys, CA 91406-3807, USA
(818) 374-5857 • FAX (818) 374-5856 • www.jensen-transformers.com